

CO transmitter CO 110

KEY POINTS

- Range from 0 to 500 ppm
- 0-10 V active output, power supply 24 Vac/Vdc (3-4 wires) or 4-20 mA output, passive loop, power supply from 16 to 30 Vdc (2 wires)
- ABS V0 housing, IP65 (depending on model), with or without display
- "¼ turn" system mounting with wall-mount plate
- Housing with simplified mounting system



FEATURES OF HOUSING

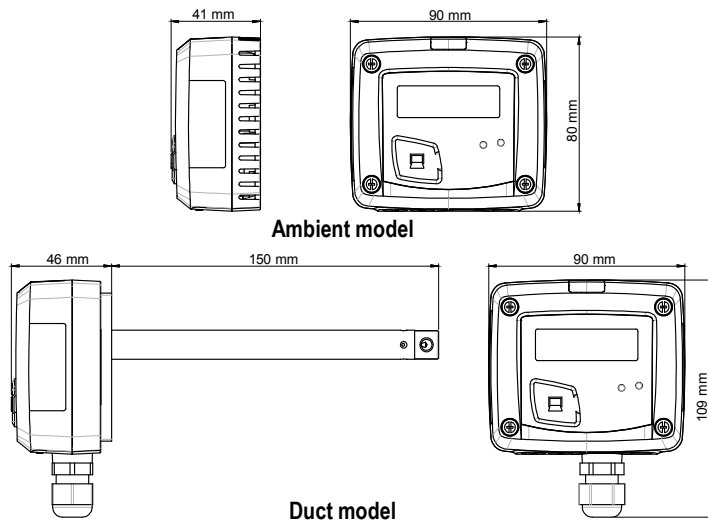

Material : ABS V0

Protection :

- duct model : IP65
- ambient model : IP20

Display : LCD 10 digits. Size : 50 x 17 mm

Height of digits : Value : 10 mm ; Unit : 5 mm

Cable gland (only for duct model) : for cables Ø 8 mm maximum

Weight : 138 g (ambient model) ; 150 g (duct model)

TECHNICAL FEATURES

Unit of measurement	ppm
Measuring range	From 0 to 500 ppm
Accuracy*	±3 ppm or 3% of the measured value
Type of sensor	Electrochemical sensor
Life-time of the sensor	5 years
Response time	T63 = 35 s
Resolution	0.1 ppm
Type of fluid	Air and neutral gas
Conditions of use (°C/%RH/m)	From 0 to +50 °C. In non-condensing condition. From 0 to 2000 m.
Storage temperature	From -10 to +70 °C

*All the accuracies indicated in this technical datasheet were stated in laboratory conditions, and can be guaranteed for measurements carried out in the same conditions, or carried out with calibration compensation.

PART NUMBER

To order, just add the codes to complete the part number :

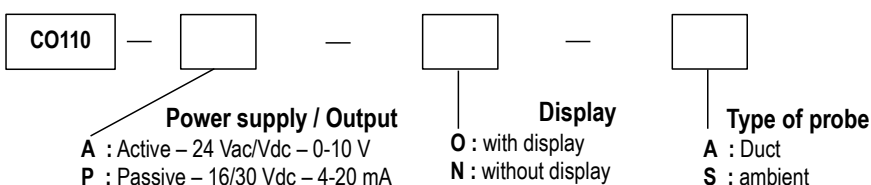

Example : CO110-POA

CO transmitter, 4-20 mA passive transmitter, with display and duct probe

TECHNICAL SPECIFICATIONS

Output / Power supply	<ul style="list-style-type: none"> - active 0-10 V (power supply 24 Vac/Vdc \pm 10%), 3-4 wires - passive loop 4-20 mA (power supply 16/30 Vdc), 2 wires - Common mode voltage <30 VAC - maximum load : 500 Ohms (4-20 mA) / minimum load : 1 K Ohms (0-10 V)
Consumption	2 VA (0-10 V) or 0.6 VA (4-20 mA)
European directives	2004/108/EC EMC ; 2006/95/EC Low Voltage ; 2011/65/EU RoHS II ; 2012/19/EU WEEE
Electrical connection	Screw terminal block for cables from 0.05 to 2.5 mm ² or from 30 to 14 AWG Carried out according to the code of good practice.
Communication to PC	USB-mini DIN cable
Environment	Air and neutral gas

CONNECTIONS

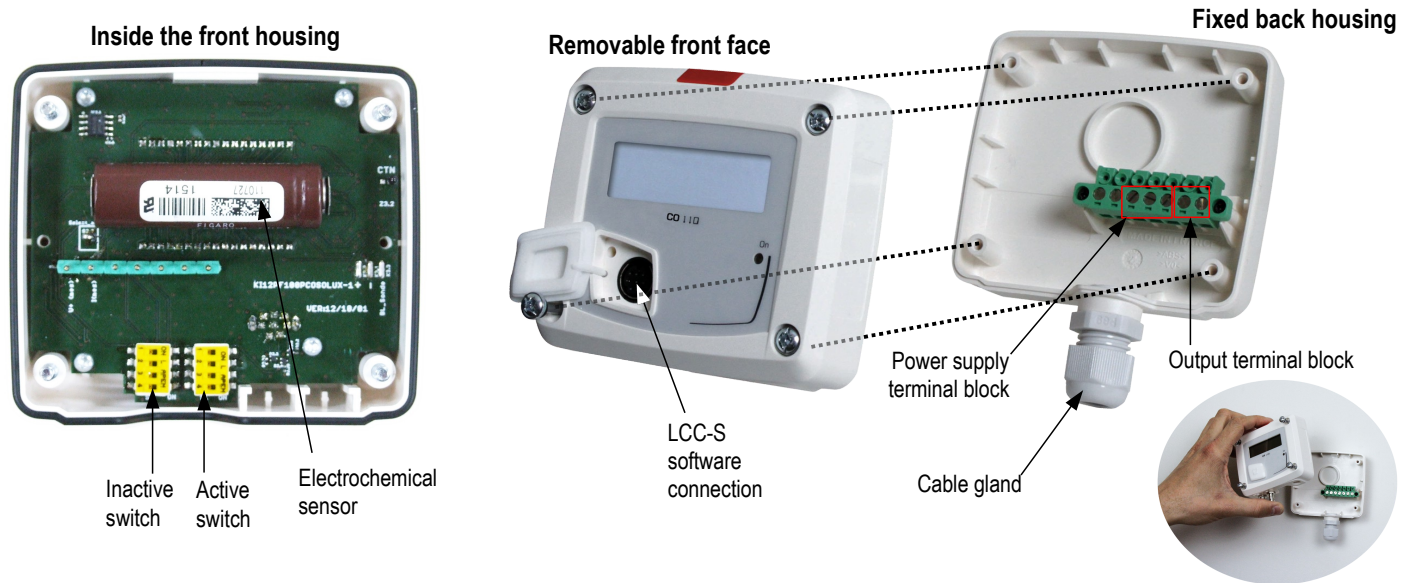

ELECTRICAL CONNECTIONS – as per *NFC15-100 standard*

⚠ This connection must be made by a qualified and trained technician. To make the connection, the transmitter must not be energized.

For **CO110-A** models with **0-10 V** output – active :

⚠ To make a 3-wire connection, before powering up the transmitter, please connect the output ground to the input ground. See drawing below.

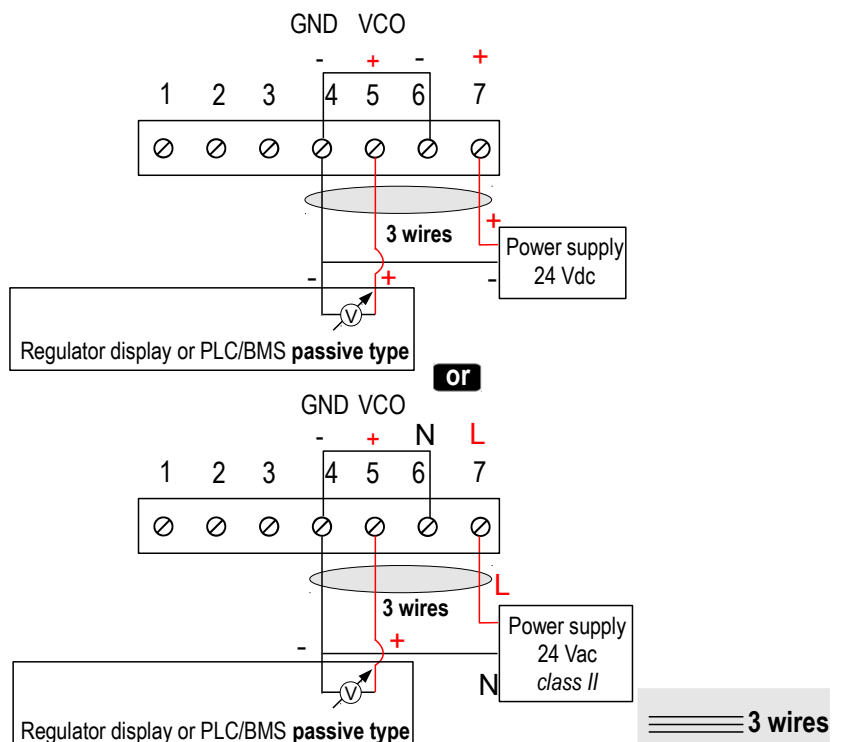
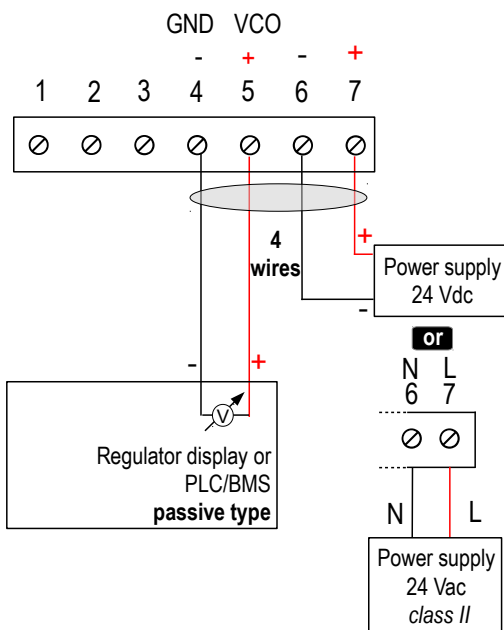

≡≡≡≡ 4 wires

≡≡≡≡ 3 wires

For CO110-P models with 4-20 mA output – passive :

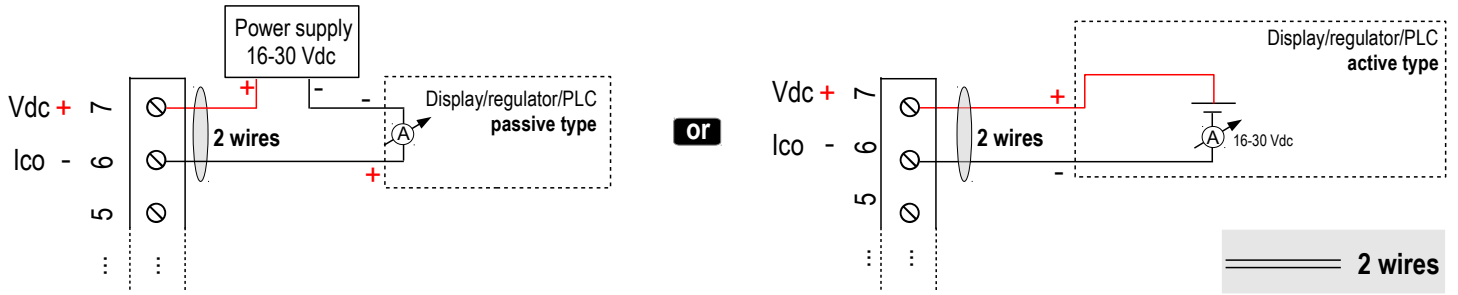

SETTINGS AND USE OF THE TRANSMITTER

> Configuration



To configure the transmitter, it must not be energized. Then you can make the required settings thanks to the DIP switches as shown on the drawing below. When the transmitter is configured, you can power it up.

To configure the transmitter, unscrew the 4 screws of the housing then open it. DIP switches allowing the different settings are accessible.

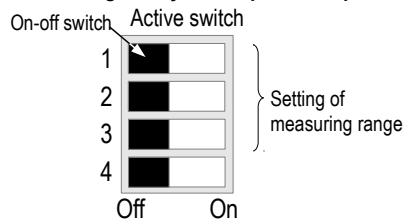

> Measuring range setting

To set a measuring range, put the on-off switches 2, 3 and 4 as shown below :

Measuring ranges	Configuration via PC (from 0 to 500 ppm by default)	From 0 to 100 ppm	From 0 to 200 ppm
Combinations			

CONFIGURATION VIA LCC-S SOFTWARE (optional)

An easy and friendly configuration with the software !

It is possible to configure intermediary ranges.

Attention : the minimum difference between the minimum scale and the maximum scale is 20.

Example : for a 0-500 ppm transmitter, the minimum delta is 20 ppm. So the transmitter could be configure from 0 to 70 ppm from 0 to 20 ppm.

- To access to the configuration via software :
 - Set the switch as shown beside.
 - Connect the cable of the LCC-S to the connection of the transmitter.
- To configure the transmitter, please refer to the LCC-S user manual.

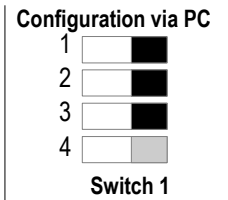

Caution : The configuration of the parameters can be done either by DIP switch, or by software (you cannot combine both solutions).

MOUNTING

To mount the transmitter, mount the ABS plate on the wall (drilling : $\varnothing 6$ mm, screws and pins are supplied).

Insert the transmitter on the fixing plate (see A on the drawing beside). Rotate the housing in clockwise direction until you hear a "click" which confirms that the transmitter is correctly installed.



Ambient model has not any fixing plate.
4 fixing holes are inside the back housing.
Use them to install the transmitter on the required location.

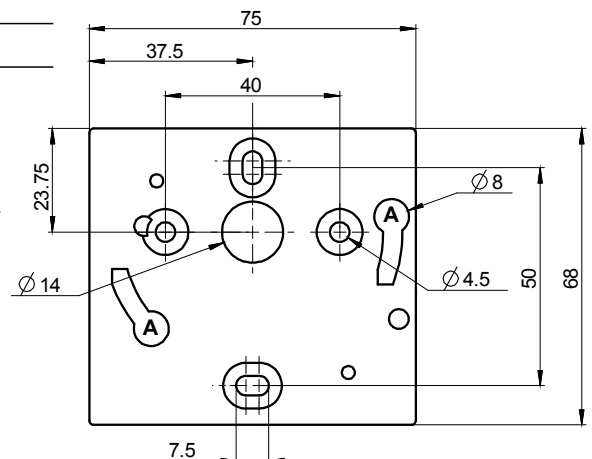

POSITIONING OF THE PROBE

For duct models, the positioning of the probe is important to get accurate measurements : the hole located next to the screw at the end of the probe must face the air flow.

Procedure to modify the positioning of the end of the probe :

- > Unscrew the screw.
- > Turn the end of the probe : the hole must face the air flow.
- > Replace the screw.

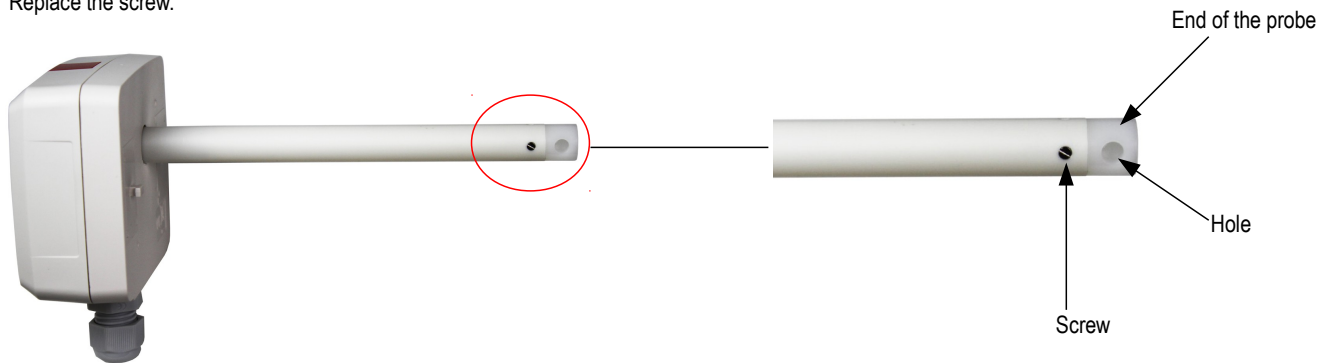

MAINTENANCE

Please avoid any aggressive solvent. Please protect the transmitter and its probes from any cleaning product containing formol, that may be used for cleaning rooms or ducts.

OPTIONS AND ACCESSORIES

- **KIAL-100A** : Power supply class 2, 230 Vac input, 24 Vac output
- **KIAL-100C** : Power supply class 2, 230 Vac input, 24 Vdc output
- **LCC-S** : configuration software with USB cable



Only the accessories supplied with the device must be used.

PRECAUTIONS FOR USE

Please always use the device in accordance with its intended use and within parameters described in the technical features in order not to compromise the protection ensured by the device.



Once returned to KIMO, required waste collection will be assured in the respect of the environment in accordance with European guidelines relating to WEEE.

www.kimo.fr



EXPORT DEPARTMENT

Tel : + 33. 1. 60. 06. 69. 25 - Fax : + 33. 1. 60. 06. 69. 29

e-mail : export@kimo.fr

Distributed by :

technical
expanding possibilities

t 905-575-1941 **f** 905-575-0386

tf 1-866-327-8731 1-86-MEASURE-1

@ sales@technical-sys.com

w www.technical-sys.com